

DARK HAVENS: Confronting Hidden Money & Power

5 & 6 April 2019
Press Coverage



Media Overview

Articles

Furtherfield, 25.09.2019, *Review of Dark Havens*,

tip -April 2019, Stadtleben Highlights

Voice for Transparency - 18.04.2019, *Repercussions for revealing corruption*

Lola Magazine - April 2019, *The Disruption Network Lab Presents Dark Havens: Confronting Hidden Money & Power - Uncovering the “Shadow Economy”*

Clot Mag – 21.04.2019, *The Disruption Network Lab Presents Dark Havens: Confronting Hidden Money & Power - Uncovering the “Shadow Economy”*

Schweinwerfer – June 2019, *Dunkle Häfen*

Meeting with Reporters ohne Grenze

Interviews

Transitloungeradio – Podcast Series - The Disruption Network Lab Presents Dark Havens: Confronting Hidden Money & Power Uncovering the “Shadow Economy”

Bonner Rundschau – 20.03.2019 , *Neue Technologien auf dem Prüfstand*

FURTHERFIELD



Review of DARK HAVENS: Confronting Hidden Money & Power

29/05/2019

Lorin Decarli

The leaking of the Panama Papers in 2015 (and later the Bahamas and the Paradise Papers), have exposed the extent to which part of the richest world elite has a consolidated habit of avoiding paying taxes. The leaks from the Panamanian global law firm Mossack-Fonseca have uncovered the illegal assets and murky fiscal dealings of hundreds of powerful individuals and corporations, providing detailed information on their bank accounts and shell companies.

Two years after the release of the Panama Papers, the 15th conference of the Disruption Network Lab "DARK HAVENS: Confronting Hidden Money and Power" was held in Berlin Kunstquartier Bethanien, by Disruption Network Lab Berlin, April 5-6 2019. It brought together the researchers and individuals who were part of global investigations, taking severe personal risks to expose the hidden money and power structures. This time, the Disruption Network has focused on the issues of secrecy, financial corruption and tax havens to identify informational, political, technological and artistic countermeasures to such topics.

Tax evasion is a colossal and complicated issue. Several unexpected countries that offer comparatively low corporate tax-rates and protect bank secrecy can indeed be included within a broader definition for tax haven. Many receive information for abroad assets and income but do not share with outside authorities information about what happens domestically, to such an extent that the Caymans and Bahamas are somehow far less permissive than states such as Delaware and Nevada in the US, where shell companies are very easy to open and bank secrecy is essential.

Simon Shuster, Nicholas Shaxson and Maira Martini in the panel "HIDDEN TREASURES: How the Global Shadow Economy Drives Inequality"



Author and researcher Nicholas Shaxson opened the conference by describing an articulated system that contributes to global inequalities and shifts of wealth from poor to rich. Transparency International's Senior Policy Advisor Maira Martini described the role of banks in cross-border corruption cases, presenting schemes connecting shell companies, multiple offshore bank accounts and money laundering. The panel moderated by Simon Shuster discussed why, despite the global outrage caused by the Papers, the practice of billionaires and corporations stashing their cash in tax havens is still common.

Mossack-Fonseca was indeed just one of the many providers in the off-shore industry of Panama. And Panama is just one of the many tax havens, where complacent governments guarantee international investors that they will neither regulate nor prosecute their conducts, nor share information about their activities.

EU Institutions turn a blind eye to billions of euro's worth of wealth that disappear not always out of sight of local tax authorities across Europe. The MEPs recently stated that seven member states (Belgium, Cyprus, Hungary, Ireland, Luxembourg, Malta and the Netherlands) "display traits of a tax haven and facilitate aggressive tax planning". Obviously, tax avoidance is not related just to exotic illegal corporate offshore activities.

The leaks confirmed that several British satellite havens (E.g. Virgin Islands, Cayman, and the Channel Islands) and the City of London are closely linked through commercial and legal ties, with high chances for dark money to flow through the UK's overseas territories and crown dependencies undetected. As many participants to the conference pointed out, Brexit can just worsen this situation.

The political and economic ramifications of the leaks suggest that such a system is hard to disrupt, since it guarantees the very rich and powerful elite of the world will withhold power. 50% of the wealth held in tax havens belongs to households with more than USD 50 million in net wealth: just ultra-high-net-worth individuals can afford activities in said tax havens as they carry very high fees, although the fees are substantially less than paying taxes owed.

Reporters Ryan Gallagher and Friedrich Lindenberg from the Organized Crime and Corruption Reporting Project (OCCRP) discussed the ethics of massive data leaks, security and secrecy in juxtaposition to openness and transparency, as well as source protection and collective mobilization in the analysis of the material.

Ryan Gallagher, Friedrich Lindenberg and Tatiana Bazzichelli in the panel "LEAKING MASSIVE DATASETS: Security, Openness, and Collective Mobilisation"



Considering the amount of leaked data (16.8 million financial confidential electronic documents about offshore investments in three years), a collective mobilization is necessary to analyse them all and uncover injustices. By these means people can force companies and privates to end their systematic tax evasion that lies at the heart of the global economic system.

How can we then try to find a road in there? It is important to share information, also creatively, with tools like "The Offshore Tour Operator" a GPS prototype presented during the conference, that guides the walk of the user through the database of the Panama Papers, in search of the physical traces of the offshore banking within the city landscape. A group of twenty people could actually see the tool in action, guided throughout Berlin by two members of RYBN.ORG, the Paris-based collective founded in 1999 that created this project.

Projects and online platforms like this could be part of the solution. They are open to individuals, tax experts and reporters too, not just law enforcement officials and activists and we all shall enhance access and participation.

In 2018, the net wealth of 26 billionaires was the same as the poorest 3.8 billion people of the world (Oxfam). An extreme disparity-rate accelerating year by year, that considers just official capitals and investments, whilst there is a whole universe of dark money stored in tax havens impossible to calculate. The impact of such a private corruption affects public fundamental services like hospitals and schools and is devastating. It's an inequality comparable to that of Versailles before the French Revolution, as the documentary "Panama Papers," that had its German Premiere during the Disruption Network Lab conference suggests.

The documentary shows how millions of files were leaked by anonymous whistle-blower John Doe to journalists of the Süddeutsche Zeitung, Frederik Obermaier and Bastian Obermayer, who shared them with the Washington-based International Consortium of Investigative Journalists (ICIJ) and coordinated a worldwide investigation, setting up an incredible enterprise.

The Keynote Frederik Obermaier (on the right) during the panel "PANAMA PAPERS: How the Rich and the Powerful Hide Their Money" moderated by Max Heywood (Transparency International)



Obermaier described his choice of opening the information to other colleagues as the only possible way of analysing the information, considering that a single person would need 32 years to get through 1.4 Terabyte of leaked data. The efforts of 376 journalists from 76 countries working in secret for two years until the simultaneous publication in April 2016, was awarded with the Pulitzer Prize.

Following the Papers release more than thousands official investigations started and dozens criminal cases have been initiated. Such an activity has brought more than USD 1.2 billion back onshore as governments around the world have recouped money in fines and back taxes (UK 253 million, Germany 150 million). Participation works!

However, whistleblowers and investigative journalists working on tax avoidance and international frauds are criminalised and killed. Obermaier reported that 17% of the countries involved in the Papers has seen backlash against journalists who covered the investigation, instead of offering them effective legal protections.

To reverse this trend, the conference focused on the personal impact of investigative journalism and whistleblowing for those who expose offshore corruption and tax havens. The stories of women suffering the consequences of their anti-corruption activities were presented in a panel moderated by Michael Hornsby, communications officer at Transparency International.

The video "Daphne Caruana Galizia. Anti-Corruption Award Winner 2018" directed by David Velduque, opened the discussion with an interview of Paul Caruana Galizia, son of Daphne, talking about the journalist from Malta assassinated in 2017 after she uncovered a thread of hidden connections linking major multinational deals and global money-laundering operations to the heart of Malta's government.

Exposing injustice caused consequences to the Turkish journalist Pelin Ünker, who – as she narrated – was sentenced to 13 months for writing about the dodgy dealings of the former Turkish prime minister Binali Yıldırım and his sons who were found to be stashing cash in a Maltese shell company (Update: one month after the conference, on the 6th of May, Pelin Ünker's prison sentence was overturned by an appeal court, although she still has to pay a fine).

The experience of Stéphanie Gibaud, a whistleblower from France, who revealed tax evasion and fraud by the investment bank UBS, and Khadija Ismayilova, Azerbaijani investigative journalist and radio host well known for her reports on corruption in Azerbaijan, completed the panel. Due to a travel ban, this last one could just take part to the Disruption Network Lab-conference with a video, by which she described her case made of trumped up accusations, imprisonment, 3.5 years in probation and a 2-year ban on professional activity. As she narrated, she has been spied and blackmailed by her Government for years, and she is still not free.

The importance of collaborative networks of investigative journalists was something that all those taking part in the conference mentioned. Thanks to organisations like OCCRP, that connects 45 non-profit investigative centers in 34 countries, journalists and activists can work together to turn the tables on corruption and build greater accountability through exposing the abuse of power at the expense of the people.

Transparency could be articulated on open platforms for data sharing and technological tools able to ensure access to relevant information, control and participation, fostering accountability. Documents are still available and the still have a lot to say: a collective mobilization could support the work of investigative journalists and oblige authorities to act.

Estimates report that offshore financial wealth is worth USD 7.6 trillion, the 8% of global household financial wealth (Zucman, 2015) others indicate though that super-rich might hold up to USD 32 trillion in offshore havens, excluding non-financial assets as real estate, gold and other undetectable investments (Henry, 2016). Our economic systems are hostage of these numbers. Banks hold massive amounts of loans in tax-haven-based businesses, a small economic elite makes and escapes rules, undermining democracies via financial deregulations, feeding social injustice.

Financial secrecy is a key facilitator of money laundering, corruption and financial crimes. For too long it's been clear that corporations simply shift profits to places where taxes are low, whilst ultrawealthy households hide dark money in a handful of tax shelters to avoid paying their fair share. What is then the opportunity connected with the preservation of bank secrecy, considering that it just increases inequalities and violations of human and social rights?

Pelin Ünker (right), Stéphanie Gibaud (middle) and the moderator Michael Hornsby (Transparency International).



Curated by Tatiana Bazzichelli and developed in cooperation with the Berlin-based International Secretariat of Transparency International, this Disruption Network Lab-conference was the first of the 2019 series "The Art of Exposing Injustice".

Info about the 15th Disruption Network Lab conference, all its speakers and thematic is available here: <https://www.disruptionlab.org/dark-havens>
The videos of the conference are on [Youtube](#).

To follow the Disruption Network Lab sign up for its [Newsletter](#) and get informed about its conferences, ongoing researches and projects. The next Disruption Network Lab event is planned for [June](#). Make sure you don't miss it!

The Disruption Network Lab is also on [Twitter](#) and [Facebook](#).

Photocredits: Maria Silvano for Disruption Network Lab

Stadtleben

Highlights 4-174



SuperCoop

GRÜNDUNGSTREFFEN Warum werden im Supermarkt die herkömmlich erzeugten Haferflocken in abbaubaren Papierverpackungen, Bio-Haferflocken jedoch oft in problematischen Plastikverpackungen verkauft? Eine Gruppe von lebensmittel- und umweltinteressierten Menschen plant mit dem SuperCoop in Berlin nun die Gründung eines Supermarktes, bei dem die Kund*innen Anteilseigner*innen und – drei Stunden pro Monat – Mitarbeiter*innen sind. Sie sollen auch über das Angebot in den Regalen bestimmen. Nach Vorbild von New York und Paris ist nun auch in Berlin ein SuperCoop geplant.
FORUM Factory Besselstraße 13-14, Kreuzberg, Mi 11.4., 19-23 Uhr, Eintritt frei, Anmeldung unter: supercoop.de



Fest zum Saisonstart

URBAN-GARDENING Ende Oktober wird für das Urban-Gardening-Projekt „Himmelbeet“ das letzte Stündlein schlagen: Die Pflanzenfreunde müssen ihren Platz im Wedding räumen – und wissen noch nicht, ob und wo es 2020 weitergeht. Umso mehr soll diese Garten- und Klezseason noch einmal richtig auskostet werden. Zum Auftakt wird zum Fest mit Musik, Tanz, Saatgut-Börse, Pikier-Workshops und Kinderprogramm geladen.
Himmelbeet Ruheplatzstr. 12, Wedding, Sa 13.4., 13-21 Uhr, Eintritt frei, himmelbeet.de



Talentschuppen

NACHWUCHSBÜHNE Nur knapp 40 Zuschauer passen in die Schöneberger Künstlerkneipe Barbi- che. Schauspieler*innen, Sänger*innen, Drag-Kings- and -Queens, Tänzer*innen oder sonstige Performer*innen, die gerade erst dazu ansetzen, Bühnen für sich zu erobern, finden hier ein intimes Umfeld, in dem das möglich ist. Zumal der Spaß an dem gemeinsamen Erlebnis unbedingt vor der Perfektion kommt. Die Zuschauer*innen dürfen sich überraschen lassen.
Barbiche Potsdamer Straße 151, Schöneberg, Di 16.+23.+30.4., 19 Uhr, Eintritt frei



Dunkle Oasen

KONFERENZ Sie sind super-reich und wollen noch reicher werden: Firmenbosse, Fußball-Stars oder Staatspräsidenten, die ihr Geld über Offshore-Firmen in Steueroasen verstecken. Im Rahmen der Veranstaltungsserie „Die Kunst, Ungerechtigkeit aufzudecken“ sprechen u.a. Journalist*innen wie Frederik Obermaier – er half, die Panama Papers aufzudecken – sowie Pelin Ünker, die Finanzkorruption in der Türkei entlarvte.
Kunstquartier Bethanien Mariannenplatz 2, Kreuzberg, Fr+Sa 5.+6.4., je 15.30-21.30 Uhr, Ticket/ Tag: 8 €, disruptionlab.org



Wenn Forscher fälschen

DISKUSSION Zitronensäure, die Körperzellen angeblich verjüngen kann oder eine Diät mit Schokolade, die garantiert schlank macht: Manche Erkenntnisse, die im Namen der Wissenschaft veröffentlicht werden, erweisen sich bei näherer Betrachtung als dreiste Fälschungen. Wie man der Irreführung durch gefakte Statistiken oder manipulierte Mikroskopfotos entgehen kann, darüber diskutieren u.a. Rüdiger Wolfrum (Max-Planck-Institut) und Joachim Heberle (FU-Berlin)
Tagesspiegel Askaniischer Platz 3, Kreuzberg, Di 9.4., 19 Uhr, Eintritt frei, Anmeld: tagesspiegel.de



Mietenwahnsinn

DEMO In Zeiten, in denen Guthaben bei Banken praktisch keine Zinsen mehr abwerfen, wurde das „Beton-gold“ entdeckt: Häuser und Wohnungen als Spekulationsobjekte. Zum massiven Nachteil der Menschen, die dort wohnen: Seit Jahren steigen die Mietpreise und Mieter*innen werden aus ihren Wohnungen verdrängt. Aber auch die Gegenwehr wächst. Am 6. April werden nicht nur hunderttausende an Menschen zu bundes- und europaweiten Demos erwartet. Es ist auch der Startschuss für das Volksbegehren „Deutsche Wohnen enteignen“.
Berliner Demo-Treffpunkt: ...



Erschüttert

AUSSTELLUNG Wenn in kriegerischen Konflikten, wie in Syrien, dem Jemen oder im Kongo mitten in bewohnten Gebieten Granaten und Bomben explodieren, ist für die betroffenen Menschen nichts mehr so, wie es einmal war. Sie verlieren Häuser, Angehörige, Gliedmaßen und ihre seelische Gesundheit. Die grausamen Folgen von Explosivwaffen auf Menschen hat der Fotograf Till Mayer dokumentiert. Unterstützt von der Organisation Handicap International zeigt er seine Bilder nun in einer Wanderausstellung.
Paul-Löbe-Haus Konrad-Adenauer-Straße 1, Tiergarten, Mo-Fr 9-17 Uhr (bis ...)



Plastikfrei leben

GESPRÄCH+LESUNG Lange Zeit ließ sich Deutschland als vorbildliche Müll-trennungs-Nation feiern. Mittlerweile aber ist klar: Durch die Existenz gelber Abfalltonnen fühlt sich die Industrie legitimiert, alles in hochproblematisches Plastik einzupacken. Und die Politik schaut der Vermüllung weitgehend tatenlos zu. Aus der Not heraus haben sich Einzelne, wie die Bloggerin Charlotte Schüller, aufgemacht, um herauszufinden, wie man trotzdem „Einfach plastikfrei leben“ kann. Nun stellt sie ihr gleichnamiges Buch vor.
Backfabrik (Clinker Lounge), Saarbrücker Str. ...



Gamesfest Berlin

MESSE Wie vielseitig und anspruchsvoll das Angebot an Computerspielen mittlerweile ist, lässt sich beim Gamesfest, dem öffentlichen Teil der Gamesweek (8.-14.4.) erleben. Von Retro-Klassikern über internationale Blockbuster bis hin zu noch nicht veröffentlichten Spielen kann man hier die ganze Bandbreite auch in der Praxis erproben. Im Rahmen des Bühnenprogramms treten neben Musiker*innen auch Influencer*innen auf, zudem finden Workshops sowie Turniere statt.
Kulturbrauerei Schönhauser Allee 36, P/Berg, Fr 12.4., 13-21 Uhr, Sa + So 13.+14.4., 11-21 Uhr, WE-Tickets: 13,99 € (10 € ...)

SuperCoop: Himmelbeet; Christian Kuehl / Talentschuppen; CCO; Thunbar / HistoLab.de/Icon; Inagay / Peter Hornant; Bensch Almeratz; Michael Sommer; Grapozz Karhosko

Repercussions for revealing corruption



Michael Hornsby

Follow

Apr 18 · 5 min read

The new EU Whistleblower protection directive is a huge step forward, but journalists and activists still need to exercise caution in their work with whistleblowers. New principles for journalists offer a much needed guide.

At the start of April, I was moderating a panel at the conference [Dark Havens](#), organised in cooperation with Transparency International by the Disruption Network Lab, a Berlin-based platform of events and research focused on the intersection of politics, technology and society.

Titled “[Silenced by power: anti-corruption journalists and whistleblowers facing violence and persecution](#),” the panel focused on the stories of three investigative journalists and a whistleblower who have faced retaliation for their work.

The Journalists

We opened with the video Transparency International produced for the 2018 anti-corruption award, given posthumously to **Daphne Caruana Galizia**. Her assassination in October 2017 has still not attracted sufficient investigation from authorities in Malta, as her sons highlighted in a statement provided for the conference.



The importance of cross-border collaboration

A thread running through these stories was the importance of collaborative networks of investigative journalists. Thanks to connections with organisations like OCCRP, the world is much smaller for an investigative journalist in Azerbaijan than it was 15 years ago, Khadija explained. After Daphne's murder, journalists worked together on The Daphne Project to complete her investigations and keep her family's quest for justice in the public eye. For Pelin, collaboration is an essential means of increasing security against legal attacks.



Pelin Ünker presented her situation as the only journalist to face charges for their reporting of the Paradise Papers. Although one case against her has recently been reluctantly dismissed by the courts, Pelin still faces a jail sentence in Turkey for her reporting of the former Prime Minister's family's shipping companies established offshore in Malta.

Investigative and broadcast journalist **Khadija Ismayilova**, under travel ban in Azerbaijan, sent a video detailing the repeated attacks levelled against her by the government, from spying and blackmail, to imprisonment, to trumped up charges. "I felt as if the government of Azerbaijan was projecting their crimes onto me," she deadpans in the video.



The whistleblowers

For the fourth story in focus, **Stéphanie Gibaud**, the UBS whistleblower from France, described her nightmarish past decade, which began after she refused to delete files detailing how her work in the PR and events department of the Swiss bank's French operation had been used to take accounts 'offshore' to Switzerland where they would be subject to lower taxes.

Years later, after being mistreated by the bank and taking her complaint to the French Ministry of Labour, she was approached by the Ministry of Finance and enlisted as an undercover witness to reveal the ongoing fraud still suspected of taking place at UBS at the time.

Hers is an example of the damage that can be done to a whistleblower's life when those acting on their information do not afford them sufficient protection. Her name was leaked to the media, who revealed her identity. Experiencing what she describes as a 'social death' and extended unemployment, she wrote a book attempting to highlight the collective plight of whistleblowers. Partly as a consequence of that book, she has been through court case after court case, some of which are still ongoing.

Stéphanie's story contrasts starkly with the example of John Doe, the still anonymous whistleblower who leaked the Panama Papers files to *Süddeutsche Zeitung*. In his keynote address at *Dark Havens*, Frederik Obermaier from *Süddeutsche* emphasized the secrecy that surrounds that person's identity, saying he could never tell anyone who it is, because he himself doesn't know.



International standards in whistleblower protection

The new [EU directive on whistleblower protection](#), if transposed properly into national law in Member States, will create a strong legal basis for protection against retaliation by employers. [Recent legislation in Australia](#) sets a standard other countries should aspire to as they implement the directive, particularly in its provision that companies must proactively implement systems to protect whistleblowers, before they experience potential detriment or retaliation.

But others who engage with whistleblowers, whether in the media, law enforcement or civil society, should continue to be extremely vigilant that their actions don't put whistleblowers in harm's way.

Once a whistleblower's identity has become known, broad public support and public recognition of their courage can serve as a buffer against further retaliation and mistreatment. As Stephanie emphasised, however, the best case scenario is usually to remain anonymous. This is not always straight forward, especially in smaller organisations. Three US organisations—the Government Accountability project (GAP), the Project on Government Oversight (POGO) and Public Employees for Environmental Responsibility (PEER)—have recently published a guide for Whistleblowers called [Caught Between Conscience & Career: Expose Abuse Without Exposing Your Identity](#).

The Perugia Principles

Simultaneous to the event in Berlin, journalists were meeting in Perugia for the international festival of investigative journalism. There, they agreed the following principles for working with whistleblowers in the digital age.

- 1. First, protect your sources. Defend anonymity when it is requested.*
- 2. Provide safe ways for sources to make 'first contact' with you, where possible.*
- 3. Recognise the costs of whistleblowing for the whistleblower, and prompt them to think through ahead of time how to cope when the story breaks.*
- 4. Verify material focusing on the public interest value of the information, not on your view of the attitudes or opinions of the source or whistleblower.*
- 5. Take responsibility for your digital defence and use encryption. Even though encryption may not completely defend your source, it offers important first-line protection.*
- 6. Determine the biggest threats to you and your source, and what specific steps you need to take to protect both of you*
- 7. Explain the risks of digital exposure to your source or whistleblower. On sensitive stories, train your whistleblowers in basic digital security*

8. Publish original documents and datasets in their entirety where possible and safe to do so, recognising the importance of datasets in stories.

9. Securely delete data provided by sources, when asked, to protect confidential sources, consistent with ethical, legal and employer obligations.

10. Ensure any digital drop boxes for confidential sources and whistleblowers offer a good level of security, and, for higher-risk materials, anonymity.

11. Understand the country, regional and international legal and regulatory frameworks for protecting confidential sources and whistleblowers.

12. Encourage news publishers to practice their responsibility to provide proper data security for journalists, sources and stored materials, along with appropriate training and policies to guide journalists.

These principles, like the EU directive, don't have the power to undo damage already done. But, hopefully, one of the lasting impacts of the Panama Papers can be a better understanding of best practice in working with whistleblowers that will increase their safety and include them in the collaborative, protective approach that today's best investigative journalism aspires towards. As Stephanie's story illustrates, they should guide the actions of authorities, too.

Follow me on Twitter @MDA_Hornsby

Journalism

Whistleblower

Corruption

Paradise Papers

Daphne Caruana Galizia



10 claps



Michael Hornsby

Communications Officer
at Transparency
International

Follow



**Voices for
Transparency**

A collection of articles, stories, analyses and opinions from the anti-corruption movement curated by Transparency International. All views and statements represent those of the authors, and do not necessarily reflect those of Transparency International.

Follow

THE DARK HAVENS KEYNOTE SHORTLY AFTER RYBN.ORG TAKES A CLOSER LOOK AT THE EVENTS LEADING UP TO THE PANAMA PAPERS, HOW THEY WERE HANDLED, AND THE POLITICAL BLOWBACK OF THE LEAK. THE ANONYMOUS WHISTLEBLOWER ULTIMATELY REVEALED AN ALTERNATE UNIVERSE IN WHICH THE GLOBE'S POWERFUL ARE ABLE TO MITIGATE LAWS THEY TERM INCONVENIENT. FREDERIK OBERMAIER OF THE *SÜDDEUTSCHE ZEITUNG* WILL UNDERLINE THE IMPORTANCE OF PROTECTING SUCH WHISTLEBLOWERS AS WELL AS DETAIL HOW ENTIRE GOVERNMENTS LIKE IRAN AND NORTH KOREA WERE HIDING MONEY VIA THE INFAMOUS PANAMA-BASED LAW FIRM MOSSACK FONSECA. MAY HEYWOOD, TRANSPARENCY INTERNATIONAL'S GLOBAL OUTREACH AND ADVOCACY COORDINATOR, WILL MODERATE THE CONVERSATION.

ONE OF THE TRAGIC FEATURES OF PURSUING SUCH INVESTIGATIONS IS THE REAL THREAT OF VIOLENCE. AND JUST AS RYBN.ORG EXPOSES THE PHYSICAL ASPECTS OF MONEY LAUNDERING AND FINANCIAL FRAUD, MANY WORKING TO EXPOSE SUCH NETWORKS RUN THE RISK OF BEING SILENCED. IN THE FOLLOWING PANEL WITH PELIN ÜNKER, A MEMBER OF ICIJ, STÉPHANIE GIBAUD, THE WHISTLEBLOWER BEHIND UBS' TAX EVASION PRACTICES, KHADIJA ISMAYILOVA, AN INVESTIGATIVE JOURNALIST FROM TURKEY, THE GROUP WILL TOUCH SPECIFICALLY ON THE CASE OF DAPHNE CARUANA GALIZIA. GALIZIA WAS RESPONSIBLE FOR EXPOSING THE MYRIAD CONNECTIONS THAT UNVEILED THE MALTESE GOVERNMENT'S PRINCIPAL ROLE IN A SERIES OF GLOBAL MONEY-LAUNDERING OPERATIONS. AS A RESULT, SHE WAS ASSASSINATED ON OCTOBER 16, 2017. WHILE NOT NEARLY AS SOMBRE, BOTH ÜNKER AND GIBAUD WILL RECOUNT THEIR TRIALS AND TRIBULATIONS WHEN FOLLOWING SIMILAR LEADS IN TURKEY AND FRANCE.

The Disruption Network Lab Presents Dark Havens: Confronting Hidden Money & Power

Uncovering the "Shadow Economy"



✍ LIAM KELLY

DATE: 5.4.2019 – 6.4.2019

VENUE: STUDIO 1, KUNSTQUARTIER BETHANIEN

TIME: VARIES

FROM APRIL 5 TO 6, THE DISRUPTION NETWORK LAB WILL BRING TOGETHER A NUMBER OF JOURNALISTS AND THINKERS WHO RISKED THEIR LIVES WRITING ABOUT THE CRIME AND CORRUPTION IN THE GLOBAL FINANCE SECTOR. THE CONFERENCE, DARK HAVENS, WILL SPECIFICALLY LOOK AT ALL SIDES OF THE INTERCONNECTED TAX LOOPHOLES THAT KEEP THE SUPER RICH AND POWERFUL IN CHARGE. FOLLOWING THE TWO-DAY EVENT IS A “PSYCHO-GEOGRAPHIC” TOUR OF BERLIN FROM ARTISTIC RESEARCH PLATFORM RYBN.ORG WHICH WILL EXPOSE THE PHYSICAL HUBS THROUGH WHICH MANY THESE HIDDEN RIVERS OF MONEY PASS. UNFORTUNATELY, THE LIMITED NUMBER OF TICKETS HAS ALREADY SOLD OUT AT THE TIME OF PRESS.

INCOME INEQUALITY, DATASETS, AND A DOCUMENTARY

THE OPENING PANEL ON FRIDAY DIVES INTO HOW NETWORKS OF ILLICIT TAX HAVENS ARE SOME OF THE GREATEST PROPAGATORS OF ECONOMIC INEQUALITY IN THE WORLD. PANELISTS NICHOLAS SHAXSON, AUTHOR OF TREASURE ISLANDS: DIRTY MONEY, TAX HAVENS AND THE MEN WHO STOLE YOUR CASH, AND MAIRA MARTINI, SENIOR POLICY ADVISOR OF TRANSPARENCY INTERNATIONAL, WILL CONNECT THE DOTS BETWEEN SHELL COMPANIES, SECRECY, AND HOW, THROUGHOUT HISTORY, THESE FINANCIAL MECHANISMS HAVE BEEN TIED TIGHTLY TO THOSE WHO HOLD THE REIGNS OF POWER. THE TWO SPEAKERS WILL DRAW EXPERT KNOWLEDGE FROM THEIR RESPECTIVE ROLES AS A JOURNALIST AND AS A POLICY ADVISOR.

NICHOLAS SHAXSON HAS WRITTEN EXTENSIVELY ON HOW CURRENT MONEY MARKETS CONTINUOUSLY TRANSFER MONEY AWAY FROM THE MARGINALLY POOR TO THE SUPREMELY RICH. HE IS REFERENCED HEAVILY IN THE DOCUMENTARY THE SPIDER'S WEB: BRITAIN'S SECOND EMPIRE WHERE HE DEVELOPS THE THESIS THAT BRITISH COLONIALISM HAS NOT DISAPPEARED, IT HAS SIMPLY CHANGED INTO A SERIES OF DISPARATE TAX HAVENS ALL OVER THE WORLD.

FOR HER PART, MAIRA MARTINA WILL BE REPRESENTING TRANSPARENCY INTERNATIONAL, A SWISS COALITION LOOKING TO COMBAT THE TYPES OF FINANCIAL CORRUPTION EVIDENCED IN DOCUMENTS LIKE THE PANAMA PAPERS. SHE HAS WRITTEN EXTENSIVELY ON HUNGARY'S "GOLDEN VISA SCHEME," ESTONIA'S PROBLEMS WITH MONEY LAUNDERING, AND HELPED TO PAINT A CLEARER PICTURE FOR HOW CORRUPTION OCCURS IN THE EUROPEAN UNION.

FOLLOWING THIS DISCUSSION IS A PRACTICAL GUIDE FOR HOW BEST TO APPROACH MASSIVE DATASETS LIKES THOSE OF THE PANAMA, BAHAMA, AND PARADISE PAPERS. IN TOTAL, THE 25.2 MILLION FINANCIAL DOCUMENTS WERE ALL LEAKED TO THE *SÜDDEUTSCHE ZEITUNG* WHO THEN PASSED ALONG THE INFORMATION TO THE INTERNATIONAL CONSORTIUM OF INVESTIGATIVE JOURNALISTS (ICIJ). THE LATTER GROUP LAUNCHED AN INTERNATIONAL INVESTIGATION WHICH BROUGHT INTO QUESTION THE FINANCIAL WORKINGS OF MANY GOVERNMENTS AND LEADERS. IN THE FIRST, THE SHEER QUANTITY OF RAW INFORMATION IS A GRUESOME TASK TO PROP UP A NARRATIVE, BUT THE ETHICS BEHIND SUCH WORK ALSO DEMAND ONE'S ATTENTION.

TO SORT BETWEEN THESE TWO FORCES, RYAN GALLAGHER, INVESTIGATIVE REPORTER FOR *THE INTERCEPT*, FRIEDERICH LINDENBERG, THE DATA TEAM LEAD AT THE ORGANIZED CRIME AND CORRUPTION REPORTING PROJECT (OCCRP), AND TATIANA BAZZICHELLI, THE DIRECTOR OF THE DISRUPTION NETWORK LAB WILL HASH OUT THE MULTI-FACETED ARGUMENTS FOR AND AGAINST SECRECY AND TRANSPARENCY.

THE CLOSING EVENT WILL SCREEN ALEX WINTER'S DOCUMENTARY ON THE PANAMA PAPERS STORY. IT CHARTS THE TRAJECTORY OF THE INITIAL DATA LEAKS ALL THE WAY TO THE GRAVE CONCLUSIONS FOR HOW OUR SOCIETY FUNCTIONS. WHAT MIGHT SEEM LIKE SIMPLE TAX EVASION, FRAUD AND CRONYISM, IS ACTUALLY AN EXTENSIVE MESH OF POWER PLAYS TO MANIPULATE WORLD GOVERNMENTS FOR PROFIT.

MAKING REAL THE IMAGINARY, MATTRESS MONEY, AND WHISTLEBLOWERS

MAKING REAL THE IMAGINARY, MATTRESS MONEY, AND WHISTLEBLOWERS

THE LARGEST BARRIER FOR JOURNALISTS AND DATA SCIENTISTS WORKING TO UNEARTH THE ILLICIT NETWORK OF GLOBAL FINANCE IS THE OPACITY OF THE EVIDENCE. ONLY THANKS TO GENEROUS DATA LEAKS WERE WE EVER ABLE TO BEGIN TO UNDERSTAND THE EXTENT OF THE CORRUPTION. AFTER THAT, THE GREATER PUBLIC STILL NEEDS TALENTED CURATORS TO DEVELOP A CLEAR ACCOUNT OF WHAT THE DOCUMENTATION MEANS. THUS, IN AN ATTEMPT TO MAKE REAL THE OCEAN OF NUMBERS, RYBN.ORG WILL PRESENT THEIR WORK THE GREAT OFFSHORE PROJECT. THE WORK LOOKS TO DECIPHER THE LEGALESE THAT SOOTHES CRITICS FROM GETTING A FULL GRASP OF WHAT IS ACTUALLY HAPPENING. READING THROUGH FORMALIZED AGREEMENTS, CONTRACTS, AND PRESS RELEASES RARELY OFFER ANY REAL INSIGHT INTO THE INNER WORKINGS OF ARRANGEMENTS, ILLEGAL OR OTHERWISE. OUTSIDE OF SEMANTICS, RYBN.ORG ALSO ATTEMPT TO SHOW HOW OFFSHORE FINANCE LEAVES PHYSICAL MARKS ON THE LOCATIONS THAT THEY LEVERAGE.



Found objects from The Great Offshore Project's exhibition at Espace Multimédia Gantner in 2017.

THE FINE PRINT

THE EVENT BEGINS FRIDAY, APRIL 6, WITH DOORS OPENING AT 17H30 AND THE FIRST TALK HAPPENING AT 18H. THE ENTIRETY OF THE EVENT, OUTSIDE OF THE TOUR FROM RYBN.ORG, WILL TAKE PLACE AT KUNSTQUARTIER BETHANIEN, MARIANNENPLATZ. TWO-DAY TICKETS ARE €14 WHEN PURCHASED ONLINE AND €16 AT THE DOOR. ONE DAY TICKETS ARE ALSO AVAILABLE, INCLUDING THE PANAMA PAPERS SCREENING, IF USED ON APRIL 5. ALTHOUGH THE WORKSHOP WITH RYBN.ORG IS SOLD OUT, YOU CAN STILL PURCHASE A WAITING LIST POSITION FOR €15, OF WHICH WILL BE REFUNDED IF NO OPENINGS ARISE. FOR MORE INFORMATION ON THE PROGRAM AND WHERE TO BUY TICKETS, CHECK OUT DISRUPTION LAB'S LANDING PAGE FOR THE EVENT [HERE](#).

LINKS:

[PROGRAM WEBSITE & TICKETS](#)

Dark Havens, confronting Hidden Money & Power. The Art of Exposing Injustice Part 1

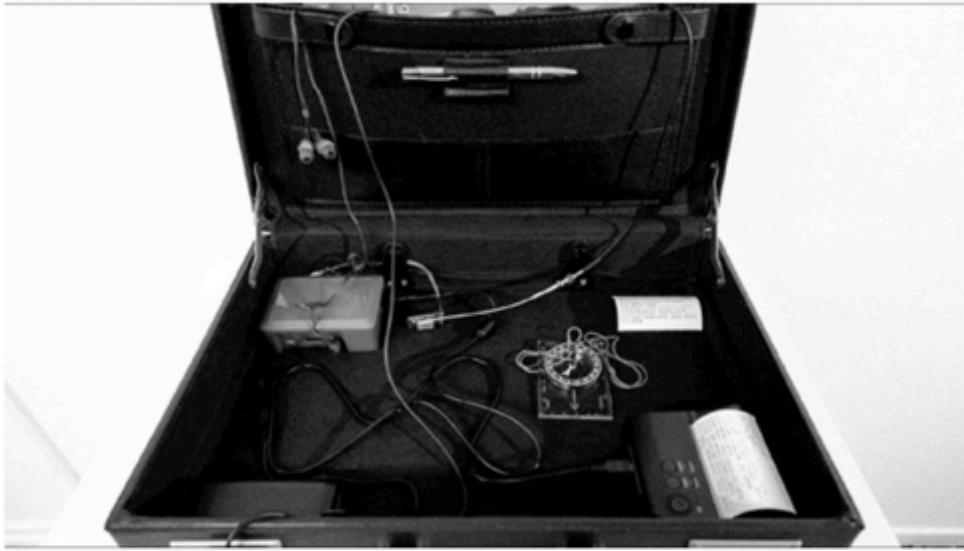

On April 5 and 6, 2019, at Kunstquartier Bethanien in Berlin, took place **Dark Havens**, a series of talks and workshops to explore the inner mechanism of the financial system, crime, corruption and wrongdoing hidden by secretive offshore companies. **Dark Havens** is organised by **Disruption Network Lab**, an ongoing platform and research focused on art, digital rights, and disruption. The Laboratory's programme is run by **Tatiana Bazzichelli**, artistic director and curator, and a team of collaborators. Among the panellists were Nicholas Shaxson, (Journalist, author of *Treasure Islands, Finance Curse*, UK/DE), Maira Martini (Knowledge Coordinator, Transparency International, BR/DE), Simon Shuster (Reporter for TIME, RU/DE), Ryan Gallagher (Investigative Reporter & Editor, The Intercept, UK), Friedrich Lindenberg (Civic Technologist, Organised Crime and Reporting Project, DE), Khadija Ismayilova (Investigative Journalist & Radio Host, AZ), and Michael Hornsby (Communications Officer, Transparency International, UK/DE).

Dark Havens is a space to meeting people from around the world who have participated in global investigations and leaks, and are whistleblowers in their corporations, facing trials and other risks. **Dark Havens** analyses the themes of tax havens and financial corruption through art, technology and activist practices and follows the scandal of **Panama Papers**. The huge leak of data containing info about secretive offshore companies occurred in 2016 when an anonymous whistleblower revealed 11.5 million financial and legal records from the Mossack Fonseca law firm, under the fake name of "John Doe", to **Bastian Obermayer**, investigative journalist, who with **Frederik Obermaier** shared the information with the International Consortium of Investigative Journalists (ICIJ). The core intention of the **Dark Havens** is to explore issues of security and openness in processes of revealing misconducts and wrongdoing of the powerful. **Dark Havens** promotes the participation of international speakers involved in leaks, investigations, whistleblowing practices, and acts of truth-telling that have suffered risks, trials, crimes, in the task of accusing financial corruption, wrongdoing, and tax havens. **Dark Havens denounces the** secretive offshore tax havens global network, and the relationships, connections, and spider web built by financial experts, bankers, accountants, world-wide institutions, laws, governments, and corporations. The offshore system links to global economic power revealing an asymmetrical wealth distribution and culminating in economic global financial crises. Furthermore, **Dark Havens** questions about the global monetary flows obscurity, hidden financial transactions, and secrecy laws, which bring inequality, risks, and poverty. According to Jonh Doe, in *John Doe's Manifesto*, "in this system – our system- the slaves are unaware both of their status and of their masters, who exist in a world apart where the intangible shackles are carefully hidden amongst reams of unreachable legalese. The horrific magnitude of detriment to the world should shock us all awake".



On April 5, *Dark Havens* presented the film screening of *The Panama Papers* (2018, USA, 94 min) a documentary by **Alex Winter** and produced by **Laura Poitras**. *The Panama Papers* documentary reveals that corrupt power-brokers are manipulating world governments and big business. The Panama Papers is the largest global corruption scandal in history. Rich, elected officials, dictators, cartel bosses, athletes, and celebrities were clients of the law firm **Mossack Fonseca** accused of practices of tax evasion, fraud, bribing government officials, rigging elections, and murder. Laura Poitras is also the director of *Citizenfour* (2014), a documentary revealing **Edward Snowden's** information about illegal wiretapping practices of the US National Security Agency (NSA) and other intelligence agencies. Furthermore, Laura Poitras collaborated with the American artist **Trevor Paglen**, who realised quite quickly that Edward Snowden's documents described a physical network of cables, which carry the world's information. The work was presented in the C-print series *NSA-Tapped Fiber Optic Cable Landing Site*, 2014.

Dark Havens continued on April 6 with the artist talk by RYBN.ORG (Extra-disciplinary Artistic Research Platform, FR) who presented "*The Great Offshore*" project, an artistic investigation on tax havens locations. Using Situationist strategies in a psycho-geographic mapping, the work represents offshore finance's physical locations and traces the transnational and financial liquid industry. **Alain Deneault** declares "*the vocabulary in use to describe offshore finance is not neutral and produces a positive, technical, legal and legitimate picture that neutralises critics*". RYBN.ORG also offered the workshop "*The Offshore Tour Operator*", on April 7, where using a psycho-geographic GPS prototype through audio indications, equipped with a compass, and accessing the database of the Panama Papers, RYBN.ORG proposed the practice of *derive* to trace in the physical infrastructure of the city territory, the

Dark Havens exposes the international situation of many countries that rule and manage through secrecy jurisdiction. Nowadays, the situation in Britain is a response to the demise of the empire, when the City of London financial interests created a web of secrecy jurisdictions that captured wealth from across the globe. According to **The Spider's Web** documentary by **Michael Oswald**, the British Empire was the largest empire, but once it fell apart and countries gain independence, the British elite of wealth privileged searched for a new method in finance to preserve their privileges. The Bank of England established protective measures, through an agreement never written, for London to become the Euro market (not in the UK, but elsewhere) and in this way, the American \$ avoided EU regulations, and the US financial market moved into London. The system is based in a secrecy jurisdiction of illegal activities such as tax evasion. The City of London, the London financial district, is an estate within an Estate, known as the City of London Corporation within an independent legal status since the Middle Ages (1066) from Britain. The City of London is structured through lobbies and a representative sits in the House of Commons. In this way, the powerful economy of the City of London shapes British policies and financial methods. The secrecy jurisdiction is based in the old system of Trusts, a mechanism of obscurity, since the Crusades and the creation of foreign lands assets trusted stewards. Trusts represent the ownership of someone's assets. A trustee is generally a lawyer and is the figure created to be exempted of taxes, through no connection in place and no trace. The trustee sets up a Trust but there is no register, no traces, and there are no obligations of reports. So, the Trust becomes invisibly protected by secrecy jurisdiction.

Moreover, there is a link between politicians and Trusts in offshore companies. British politicians have been accused by Brussels of questionable lobby practices in the City of London. The worst of it is the Government tax avoidance

hidden structures of offshore financial trading and practices of tax evasions. RYBN.ORG is a Paris-based collective founded in 1999 investigating and developing about high-frequency markets structure, algorithmic trading, and digital labour.

The Keynote speaker on April 6, **Frederik Obermaier** (Investigative Journalist, Sud-Deutsche Zeitung, DE) introduced the process of the leak of **The Panama Papers**, considering it such as one of the greatest scandals of fraud in history with such huge 2.6 TB of data revealed. Frederik Obermaier put attention to John Doe's anonymity, the whistleblower who leaked the papers, who is still an unknown identity. Frederik Obermaier explained how he received a cryptic message from John Doe, offering data from **Mossack Fonseca**, the Panamanian law firm that helped prime ministers, kings, presidents, dictators, drug cartels, Mafia clans, fraudsters, weapons dealers, and regimes like North Korea or Iran. Frederik Obermaier, with Max Heywood, also addressed the arrests, changes in legislation, the step down of several heads of government, the launch of investigations and the one billion \$ recouped as an impact resulting of the leak. Moreover, Frederik Obermaier stated the current potential risks of investigative journalists and denounced cases such as **Daphne Caruana Galizia**, investigative journalist from Malta who was assassinated on October 16, 2017, and **Jan Kuciak**. Frederik Obermaier is a Pulitzer-Prize winning reporter based in Munich and is also a member of the International Consortium of Investigative Journalists (ICIJ).

ALGOFFSHORE

ALGOFFSHORE is a Paris-based collective founded in 1999 investigating and developing about high-frequency markets structure, algorithmic trading, and digital labour.

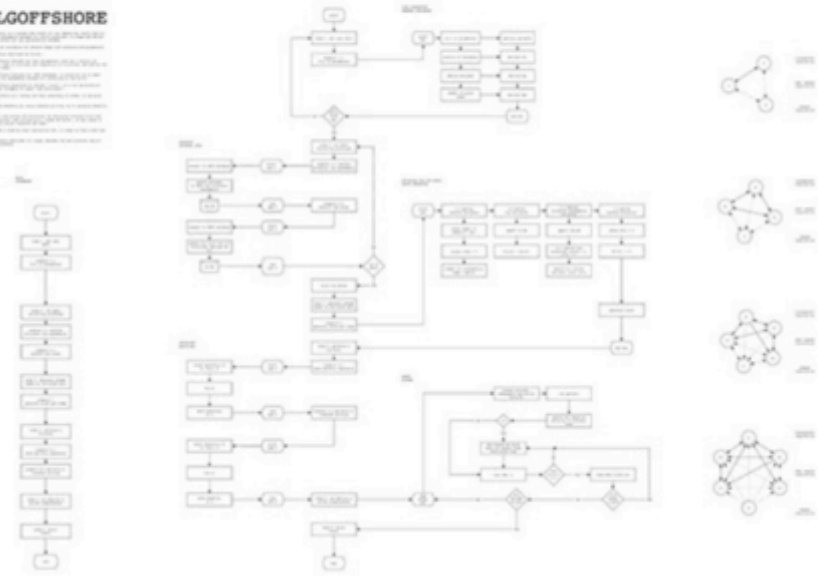

scheme, set to protect crazy business models, which is denying and cutting funding from public services. For instance, the **HM Revenue & Customs**, the UK Tax authority deals and negotiates individually and in closed doors with private corporations. **Dave Harnett**, Head of the HMRC, under taxpayers' confidentiality, did not give information, when asked about the mafia in the state, and why tax authority is ruled by laws, politics, the City of London, and bankers who are sending money to offshore territories to avoid paying taxes. The complexity and obscurity of hidden tax havens culminate within the creation of the **Private Funding Initiative (PFI)**, a structure that promotes private sector funding. The **HMRC** advises to implement **PFI** by public authorities and recommends for the tax authority to go offshore. Big banks and other corrupted business have penetrated the Government. So, most of government tax avoidance diminishes public funding and increases the making of private neoliberalism corporations and foundations. This undermines the social and human rights of citizenships. Privatisations promoted by secrecy system and tax havens, are directly linked with processes of colonial independence, establishing a post-colonialist submission and dependence in fraud, secrecy and obliteration of social justice. The power of the few against the benefits of all.

However, what will happen when tax havens begin using cryptocurrencies? How will the state regulate taxpayers? Will cryptocurrencies favour these practices of tax evasion? How can technology provide tools to citizens to contribute to a more equalitarian societal system?

This *Dark Havens* event was the first one of *The Art of Exposing Injustice* by Disruption Network Lab.

Text by Laura Netz (@lauranetz)

SCHEINWERFER

DAS MAGAZIN GEGEN KORRUPTION JUNI 2018 – 24. JAHRGANG

83



THEMENSCHWERPUNKT

Der Rechtsstaat – ein Prinzip in der Glaubwürdig- keitskrise?

25
JAHRE



TRANSPARENCY
INTERNATIONAL
Deutschland e.V.

Der Rechtsstaat
in Gefahr?
Seite 4

Umweltschutz:
Verbandsklagen als
Mittel der effektiven
Rechtsdurchsetzung
Seite 7

Rechtsstaatlichkeit:
Grundlage der
Korruptionsbekämpfung
in Entwicklungsländern
Seite 9

Dunkle Häfen

Wie sogenannte Steuerparadiese Macht und Kapital verschleiern

STEPHAN K. OHME

Das Disruption Network Lab hat in Kooperation mit Transparency International im Rahmen einer Konferenz zu Mechanismen des Finanzsystems, Kriminalität und Korruption diverse Akteure im Berliner Kunstquartier Bethanien zusammengeführt. Es ging um die Ermittlung illegitimer Kapitalverkehrs-Strukturen, deren Aufdeckung durch Whistleblower und Leaks, aber auch um die künstlerische Darstellung der Netzwerke und Methoden der Verschleierung.

Im Fokus stand die Aufarbeitung der Panama Papers – aus der Sicht von Aktivisten, Whistleblowern und Journalisten wie Frederik Obermaier (Süddeutsche Zeitung), aber auch aus der Perspektive von Künstlern. Die Präsentationen zeigten die Herausforderung der Analyse großer Datenmengen – im Fall der Panama Papers rund 2,6 Terrabyte. Die enge und vertrauensvolle Kooperation internationaler Journalistennetzwerke deckte ein globales System der Geldwäsche und Steuerhinterziehung auf. Die Veröffentlichung der Panama Papers offenbarte, wie Regelungslücken genutzt werden. Sie ermöglichte auch, konkrete Personen und Organisationen zu identifizieren. Die Vielzahl der Profiteure dieses Systems zeigt das Potential und die Verlockung der Wertschöpfung aus illegitimem Handeln. Die Papers belegen einen Systemwandel globaler Finanzbeziehungen, der bestehende regelbasierte Steuerungsmechanismen zunehmend in Frage stellt. Dabei erscheint der bislang bekannte Missbrauch eher als Spitze des Eisberges.

Künstlerische Aufarbeitung verschachtelter Finanzstrukturen

In einem „Artistic Talk“ stellte die investigative Künstlerplattform RYNE.org eine Visualisierung der Wahrnehmung von Schattenfinanzplätzen vor, die eher mit Kolonialstil, Palmen, exotischer Kultur und goldenen Stränden als mit Batterien unzähliger Briefkästen und Firmensitzen in verwahten Gebäuden, sogar Kirchen, assoziiert werden. Zweck der Darstellung war auch ein Imagewandel weg von einer ästhetisierenden Wahrnehmung finanzieller Parallel-Strukturen. Ähnliches gilt für die physische Verortung von Shell-Companies per GPS mit dem Sitz ihrer wahren Eigentümer („beneficial owners“) oder auch organisierte Stadt-Rundgänge – so im Rahmen der Konferenz in Berlin durch Elena Kagel von SUPERMARKTBerlin.de.

Whistleblower – persönliche Schicksale, die bedrücken

Am Beispiel der schweizerischen Bank UBS sowie persönlichen Berichten aus Malta, Aserbaidschan und der Türkei wurden die

Risiken von Hinweisgebenden und Journalistinnen und Journalisten thematisiert. Es zeigte sich ein Bild fehlender Regelwerke, der Gefährdung wirtschaftlicher Existenz und im Einzelfall auch physischer Bedrohung. Sie können nicht durch die investigativen Erfolge gerechtfertigt werden, bedingen diese jedoch. Bedrückend waren dabei die Darstellungen politischer Reaktionen und persönlicher Konsequenzen für Beteiligte.

Dabei wurde auch die Haltung von Transparency Deutschland bezüglich legislativer Vorstellungen für das deutsche Arbeitsrecht exemplarisch dargestellt. Für Transparency waren im Rahmen der Veranstaltung insbesondere Fragen der multilateralen, globalen Begrenzung von „illicit flows“ durch internationale Vereinbarungen relevant – konkret zum Beispiel die 5. EU-Geldwäscherichtlinie. Die nationale Umsetzung dieser Abkommen (u.a. zu „beneficial ownership“) und Diskussionen in der OECD wie der Prozess des BEPS (Base Erosion Profit Shifting) wurden jedoch nur gestreift.

Alles in allem: Konferenzen wie diese stärken das Verständnis der komplexen Bezüge und der Dimension der Herausforderung. Die Verbindung von Themen wie Steuergerechtigkeit, Korruption und Transformation erfordert komplexe Analysen und kollektive Antworten. Die Konferenz zeigte insbesondere die konkreten Erfolge des Arbeitens in Netzwerken – wie es bei der Aufarbeitung der Panama Papers exemplarisch praktiziert wurde.

Weiterführende Informationen zur Konferenz finden Sie auf <https://www.disruptionlab.org/dark-havens>.



Podiumsdiskussion auf der Konferenz „DARK HAVENS: Confronting Hidden Money & Power“ des Disruption Network Lab in Berlin

Meeting with Reportes Ohne Grenzen Deutschland

On April 9, following our conference DARK HAVENS, journalist Pelin Ünker and our Director Tatiana Bazzichelli were at Report ohne Grenzen Deutschlande (Reporters without Borders Germany) for a meeting with Anne Renzenbrink (Press & Media Relations) and Jens-Uwe Thomas (Emergency Assistance). They discussed together the case of Pelin Ünker, sentenced to jail in Turkey over Paradise Papers investigation about offshore tax havens.

More about the case of Pelin Ünker:

<https://www.theguardian.com/news/2019/jan/09/journalist-pelin-unker-sentenced-to-jail-in-turkey-over-paradise-papers-investigation>



Credit @ Reporters Ohne Grenzen Deutschland



April 21, 2019 Alternative Economies, Berlin, Dark Havens

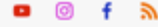

DARK HAVENS: Confronting Hidden Money & Power

Support independent radio!

DONATE

Disruption Network Lab #15 Dark Havens April 2019



#DNL15 DARK HAVENS brings together people from around the world who have been part of global investigations and leaks, have blown the whistle on corporations, been put on trial, and who have taken severe personal risks to confront hidden money and power.

Frederik Obermaier talks Panama Papers, crime & cocktails at Dark Havens

Frederik Obermaier joins me in the Transit Lounge to talk global crime & collaborative reporting, the demise of the 'lone wolf' investigative journalist, Panama Papers cocktails, writing that email to Vladimir Putin, and a thank you message to John/Jane Doe for the 11.5 million files contained in the Panama Papers.



Tax Havens + Investigative Journalism + Collaboration + Panama Papers + #DNL15

RYBN talk art, algorithmic investment and offshore tourism at Dark Havens

RYBN walk us through the *Offshore Tour Operator* to explore local traces of the transnational and liquid financial industry, and introduce classic tax avoidance schemes the Double Irish, Singapore Sling, Bermuda Black hole and Dutch Sandwich. A situationist GPS prototype for psychogeographic drift encourages you to create concrete visual representations of the opaque and offshore, reshaping the imaginary around tax havens.

Transit Lounge
Jodi Rose

0:00 8:34

SUBSCRIBE

SHARE

Kudzai Mubaiwa talks women, fin...
a month ago · 00:08:34

Friedrich Lindenberg talks mone...
a month ago · 00:06:00

Simon Shuster talks corruption, ...
2 months ago · 00:19:46

Erik Bordeleau talks fabrication, fi...
2 months ago · 00:13:08

Frederik Obermaier talks Panam...
2 months ago · 00:13:47

LISTEN NOTES



Tax Haven Tourism + Algorithmic Investment + Psychogeography + Art as Financial Optimiser + #DNL15

Nicholas Shaxson talks power, money & the finance curse at Dark Havens

Nicholas Shaxson unveils the secrets of the seriously, filthy rich and talks me through how many of the world's offshore tax havens are not only tropical islands, but actually British & OECD territories. Just what effect does that shadowy 'spider web' network of wealth extraction have on our societies? How are offshore tax havens central to the global economy? What is the finance curse? Listen to find out more!



Tax Havens + Treasure Islands + Finance Curse + Tax Justice Network + #DNL15

Stéphanie Gibaud talks whistleblowers & tax justice at Dark Havens

Stéphanie Gibaud joins me in the Transit Lounge to talk about becoming a spy for the French authorities, the impact on her life and ongoing search for justice after blowing the whistle on tax fraud at UBS.



Tax Havens + UBS + Whistleblowers + Tax Justice + #DNL15

VIDEOS: Dark Havens explores the inner mechanisms of the financial system, and the crime, corruption and wrongdoing hidden by secretive offshore companies.



SILENCED BY POWER

Anti-corruption Journalists and Whistleblowers Facing Violence and Persecution

Pelin Ünker (Freelance Journalist, Member of ICIJ.org, TR) Stéphanie Gibaud (UBS Whistleblower, FR) Khadija Ismayilova (Investigative journalist and Radio Host, AZ – on video), Moderated by Michael Hornsby (Communications Officer, Transparency International, UK/DE).

Introduced by the video: Daphne Caruana Galizia. Anti-Corruption Award Winner 2018 (Transparency International, directed by David Velduque, produced by Neurads). This panel focuses on the personal impact of investigative journalism, truth-telling, and whistleblowing in the context of exposing offshore corruption and tax havens. The aim is to cover the work of courageous women who are suffering the consequences of their activities in the field of anti-corruption, paying with their life, direct threats, travel bans, and limitations to work.

The panel is introduced by the video "Daphne Caruana Galizia. Anti-Corruption Award Winner 2018", an interview with Paul Caruana Galizia, son of Daphne Caruana Galizia, the investigative journalist from Malta who was assassinated on October 16, 2017, when a bomb placed under the seat of her car exploded. Daphne Caruana Galizia uncovered a thread of hidden connections linking major multinational deals, passport sales, and global money-laundering operations, leading her investigation to the heart of Malta's government. Journalist Polin Ünker presents the story of her reporting on the then Prime Minister's connections to corporations in Malta, as revealed in the Paradise Papers. She currently faces trial and a prison sentence in Turkey.

Stéphanie Gibaud, a whistleblower from France, tells her story of revealing tax evasion and tax fraud by the investment bank UBS.

Finally, the panel shows a video contribution by Khadija Ismayilova, the Azerbaijani investigative journalist and radio host well known for her reports on corruption in Azerbaijan, who faces 3.5 years in probation, a two-year ban on professional activity, a travel ban and other restrictions, after being imprisoned in December 2014. The panel is moderated by Michael Hornsby, communications officer at Transparency International.



HIDDEN TREASURES

How the Global Shadow Economy Drives Inequality

Nicholas Shaxson (Journalist, author of *Treasure Islands*, and *Finance Curse*, UK/DE), Maira Martini (Senior Policy Advisor, Transparency International, BR/DE). Moderated by Simon Shuster (Reporter for TIME, RU/DE). This panel introduces the topic of offshore secrecy and tax havens bringing together two experts of the field. Nicholas Shaxson will refer to his book *Treasure Islands: Dirty Money, Tax Havens and the Men Who Stole Your Cash*, where he describes the connections between global economic affairs since slavery and secretive offshore tax havens. In his analysis, dirty money, tax havens and the offshore system contributed to generate global inequalities and shift of wealth from poor to rich, as well as undermining our democracies via financial deregulations. Maira Martini will describe the schemes connecting shell companies, multiple offshore bank accounts, and money laundering, by referring to her work at Transparency International on a report on the role of banks in cross-border corruption cases.



PANAMA PAPERS: How the Rich and the Powerful Hide Their Money

Frederik Obermaier (Investigative Journalist, Süddeutsche Zeitung, DE). Moderated by Max Heywood (Transparency International Global Outreach and Advocacy Coordinator, UK/DE). The Panama Papers began with a cryptic message from an anonymous whistleblower. "Hello, this is John Doe," the source wrote. "Interested in data?" In the months that followed, the confidential source transferred emails, client data and scanned letters, from Mossack Fonseca, a notorious Panamanian law firm that has not only helped prime ministers, kings and presidents hide their money, but has also provided services to dictators, drug cartels, Mafia clans, fraudsters, weapons dealers, and regimes like North Korea or Iran. After the revelation several heads of governments had to step down, thousands of investigations were launched, approximately one billion \$ recouped. The Panama Papers proved that there is a whole parallel world offshore in which the rich and powerful enjoy the freedom to avoid not just taxes but all kinds of laws they find inconvenient. In this Keynote, Süddeutsche Zeitung investigative journalist Frederik Obermaier will reflect on the Panama Papers and their impact (arrests, changes in legislation etc.), as well as focus on the crucial roles of whistleblowers and the need to protect them. Furthermore, in conversation with Max Heywood, the dialogue will address what we learnt from The Panama Papers about political and economic power, which progress has been made against tax and dark havens, as well as how the Panama Papers have changed the way journalists think about and analyse tax havens.

• Screening: **The Panama Papers** (Directed by Alex Winter, USA, Oct 2018, 94 min).



RYBN.ORG "THE GREAT OFFSHORE"

RYBN.ORG (Extra-disciplinary Artistic Research Platform, FR) Moderated by Ela Kagel (Digital Strategist and Founder of SUPERMARKT Berlin, DE) RYBN presents the "The Great Offshore" project, an artistic investigation conducted in several tax havens. The Great Offshore addresses the question of representation of offshore finance: due to its opaque nature and the secrecy that surrounds it, it is impossible to picture. The symbolic representations that are usually in use are, as many invitations to evasion, filled by colonial images of exotic islands, of palm trees beaches and golden sands, infinite walls of numbered mailboxes, that contribute to the aestheticisation of financial power. In a similar fashion, as Alain Deneault underlines it, the vocabulary in use to describe offshore finance is not neutral, and produces a positive, technical, legal and legitimate picture, that neutralizes critics. As a consequence, either within semantics or semiotics, we face a representation crisis. To overcome this representation failure, The Great Offshore project seeks for traces of this transnational and liquid financial industry, to capture how it marks local landscapes, architectures and environments. The Great Offshore project aims to reshape the imaginary around tax havens, by re-engaging with the situationist strategies of psycho-geography, enhanced by digital and algorithmic means. During the talk, RYBN will unfold the different chapters that composed the project and its artistic, semiotic and political dimensions.

+ Workshop/Psycho-Geographic Tour of Berlin shell companies & shadow finance offices with RYBN.org.



"LEAKING MASSIVE DATASETS: Security, Openness & Collective Mobilisation"

Ryan Gallagher (Investigative Reporter & Editor, The Intercept, UK). Friedrich Lindenberg (Data Team Lead, OCCRP, Organized Crime and Corruption Reporting Project, DE). Moderated by Tatiana Bazzichelli (Director, Disruption Network Lab, IT/DE). This panel aims to pose issues of security and openness related to the analysis of data leaks and strategies of indexing data, to journalists, technical experts, researchers, and the larger civic society. In the case of the Panama Papers (April 2016) 11.5 million financial and legal records were leaked in 2015 from the Panama-based law firm Mossack Fonseca; those were followed by the Bahamas Leaks (September 2016), where 1.3 million internal company register files were leaked; later, the Paradise Papers (November 2017) were a set of 13.4 million leaked confidential electronic documents about offshore investments. This huge amount of information was all leaked to the Süddeutsche Zeitung reporters Frederik Obermaier and Bastian Obermayer, who shared it with the Washington-based International Consortium of Investigative Journalists (ICIJ) who coordinated a worldwide investigation. Ryan Gallagher (The Intercept) and Friedrich Lindenberg (Organized Crime and Corruption Reporting Project, OCCRP) will discuss the ethics of massive data leaks, security and secrecy vs. openness and transparency, as well as source protection and collective mobilisation in the analysis of the material.

Neue Technologien auf dem Prüfstand

Die Videonale im Bonner Kunstmuseum setzt sich mit dem Thema „Realität“ auseinander

Die Kuratorin und Leiterin des „Disruption Network Lab“ in Berlin, Tatiana Bazzichelli, sprach im Rahmen der Videonale mit Rundschau-Mitarbeiterin Barbara Franke über Digital Rights, Identität, das Internet und die Digitalisierung.

Frau Bazzichelli, Sie leiten das „Disruption Network Lab“ in Berlin. Der Begriff Disruption geistert derzeit, mehr denn je, durch die nationalen und internationalen Medien-Szenarien. Was bedeutet er im Hinblick auf die Digitalisierung eigentlich?

Die Digitalisierung müssen wir dazu erstmal definieren. Sie ist zu einem Schlagwort geworden, das wir benutzen, um bestimmte Konzepte attraktiver zu machen, die aber nicht unbedingt neu sind. Sie bezieht sich konkret auf die Entwicklung der Informationstechnologie und ihre Auswirkungen auf Gesellschaft, Politik und Kultur. Dazu gehört aber auch die Entstehung einer digitalen Kultur seit den 80er Jahren. Wenn wir also über künstliche Intelligenz im Sinne der Digitalisierung reden, sprechen wir besser von zum Beispiel maschinellem Lernen. Reden wir von „Big Data“, konzentrieren wir uns besser auf die Auswirkung der Technologie auf Überwachung, Privatsphäre und so weiter. Präzision ist hier wichtig.

Und Disruption?

Der Begriff stammt eigentlich aus der Wirtschaft. Clayton M. Christensen beschreibt Disruption (Störung) als einen Prozess, in dem ein neues, unscheinbares Produkt auf dem Markt etabliert wird und dann eine ganze Industrie verschlingt. In der Unternehmenskultur bedeutet Disruption aber nicht nur Störung. Disruption ist ein Prozess, der die Geschäftstätigkeit zwar stört, gleichzeitig aber neue Geschäftsformen generiert.

Wie Digitalkameras. Deren Qualität war anfänglich in vielerlei Hinsicht nicht gut, analoge Kameras wurden noch gekauft – heute sieht das komplett anders aus. Aber was hat das mit Ihrem Lab zu tun?

Es geht dabei ja um eine unerwartete Veränderung, die innerhalb eines geschlossenen Systems passiert. Unser Ziel ist es, Projekte zu untersuchen, die den Bereich der Informationstechnologie auf unerwartete Weise

stören, und Interventionen, die politischen und sozialen Wandel aus geschlossenen Systemen hervorrufen, zu beleuchten. Wir versuchen Experten zu verbinden und in einen Dialog zu bringen. Wir verbinden beispielsweise Whistleblower und Künstler, politische Entscheidungsträger und Hacker, investigative Journalisten und Aktivisten.

Die Bedeutung von Disruption ist demnach ambivalent. Glauben Sie nicht, dass die Medien mit dem Wort Disruption spielen, um im Hinblick auf die Digitalisierung Panik zu machen?

schon immer existiert haben, aber die Technologie daran eben nicht schuld ist.

Wenn Drohnen im Krieg und zu Überwachungszwecken eingesetzt werden, dann sollten wir aufhorchen. Wenn wir damit Unfälle orten können und dadurch Menschenleben retten, dann sieht das wieder anders aus. Wir sollten uns aber zum Beispiel fragen: Was wissen wir über Drohnen-Angriffe und die dahinter stehende Politik, wie funktionieren Drohnen-Systeme und welche Konsequenzen hat das auf die Zivilgesellschaft? Eine kritische Auseinandersetzung ist hier wichtig.

kostenlosen Community sein, die uns aber sehr wohl etwas kostet: nämlich unsere Privatsphäre. Das ist sehr problematisch. Facebook zum Beispiel verbietet aus Datenschutzgründen jetzt auch Fakeprofile, das heißt das Experimentieren mit ‚multiple identities‘ ist so gar nicht mehr möglich. Heute spielt politische Manipulation eine viel größere Rolle, vor allem in den sozialen Netzwerken, zum Beispiel um Hass oder Populismus zu verbreiten.

Hatespeech – auch ein wichtiger Punkt. Es gilt mittlerweile als erwiesen, dass die Hassti-

toren, die auf den Philippinen leben und leider keinerlei soziale oder kulturelle Affinität zu den Inhalten haben, die sie validieren sollen. Auf einer Konferenz zum Thema Hatespeech in unserem Lab im Mai vergangenen Jahres hatten wir die Regisseure Hans Block und Moritz Riesewieck von „The Cleaners“ zu Gast, die sich in ihrem Film mit den Content-Moderatoren beschäftigt haben. Auf der Konferenz ging es um die Untersuchung von Online-Meinungsmanipulationen, strategischer Hassrede und Fehlinformationen und deren Auswirkungen auf die Bürgerrechte.



Tatiana Bazzichelli leitet in Berlin das „Disruption Network Lab“. Im Rundschau-Gespräch im Rahmen der Videonale im Bonner Kunstmuseum äußert sie sich auch zu Reizthemen wie Hatespeech (Hasstiraden) und digitale Überwachung. Foto: Meike Böschmeyer

Naja, wir müssen definitiv darauf hinarbeiten, dass Menschen Technologien besser verstehen, auch um sie auf die Macht aufmerksam zu machen, die damit ausgeübt werden kann. Wer kontrolliert bestimmte Systeme, wer profitiert davon in politischer, wirtschaftlicher und sozialer Hinsicht? Ich jedenfalls halte technologischen Fortschritt nicht per se für schlecht, aber Menschen programmieren Technologie und spiegeln oft Voreingenommenheit in Gesellschaft, Politik und Kultur wieder.

Aber wie gehen wir dann zum Beispiel mit Drohnen und Überwachungssystemen um? Es gibt Befürworter von Drohnen, die sagen, dass politische Waffen bedauerlicherweise

Dann lassen Sie uns noch über das Internet sprechen, insbesondere Social-Media. Wie gehen wir damit um? Inwiefern beeinflusst das unsere Realität, auch im Hinblick auf unsere Privatsphäre?

Auch hier müssen wir wieder unterscheiden. Das Internet ist das Internet, Social Media ist Social Media. Für die junge Generation ist Social Media allerdings das Internet, das feministische Gruppen wie die VNS Matrix aber schon in den 90ern genutzt haben, um dank der Verwendung von Technologie mit Sexualität, Identität und sozialer Hierarchie zu spielen und so patriarchalische Strukturen aufzubrechen. Darum geht es in den sozialen Medien aber nur am Rande, viel mehr wollen wir hier Teil einer

raden auf Facebook einen wesentlichen Einfluss auf den Genozid an den muslimischen Rohingya in Myanmar hatten. Würden Sie sagen, dass Facebook mitverantwortlich dafür ist?

Ich würde sagen, dass dafür erstmal festgelegt werden müsste, wer welche Verantwortung trägt. Wir können das nicht einfach auf den Unternehmen abwälzen, die sind daran nicht alleine schuld. Die Politik zum Beispiel, die müsste da mehr regulieren, zum Beispiel in Form von Gesetzen.

Aber regulieren heißt dann auch zensurieren, oder?

Nein. Facebook zum Beispiel beauftragt für die Säuberung der Plattformen Content-Modera-

Das heißt, Sie übernehmen im Lab Aufgaben, die eigentlich Sache der Politik wäre?

Nein (lacht). Wir versuchen mit dem Lab einen Diskurs zu schaffen, um Menschen dazu zu ermächtigen, sich kritisch mit Technologien auseinanderzusetzen, sich zu informieren, um eben nicht Opfer von Hatespeech oder Überwachung zu werden.

Mehr Informationen zum „Disruption Network Lab“ mit Sitz in Berlin mit allen kommenden Veranstaltungen findet man unter www.disruptionlab.org; die Videonale.17 – Festival für Videos und zeitbasierte Kunstformen – läuft im Kunstmuseum noch bis zum 14. April; Di-So 11 bis 18 Uhr, Mi 11 bis 21 Uhr; Friedrich-Ebert-Allee 2]